



One Technology Court, Montgomery, AL 36116
Telephone: 334-280-4400

Ed Castile
 Director

Karen McGraw
 CFO

<p>Invitation to Bid #989 Aluminum — Various Locations, as needed</p>
--

Bid must be received Before: **Date: June 19, 2024 Time: 04:00 PM CST**

Bid Opening: **Date: June 20, 2024 Time: 10:00 AM CST**

Submit Bid Proposal to: **AIDT Bid Number 989**
Attention: Ashley Price
One Technology Court
Montgomery, AL 36116

Table of Contents		Page
NOTES TO BIDDERS		2
CHECKLIST FOR BID SUBMISSION		3
INSTRUCTIONS TO BIDDERS		4-7
NONRESIDENT BIDDER INFORMATION		8
SALES TAX CERTIFICATION – ALABAMA DEPARTMENT OF REVENUE		8
QUALIFICATION STATEMENT		11
BID FORMS		12-16
BID PROPOSAL/SCOPE OF WORK		17

NOTES TO BIDDERS

1. Read the entire document from beginning to end and comply with all instructions, specifications, terms and conditions of the bid. Failure to follow all instructions, terms and conditions will result in the rejection of a submitted bid.
2. Bids for goods are requested using specific manufacturer, make and model information in order to establish a standard for that good based upon the need of AIDT. Vendors may bid alternative products considered to be of “equivalent” or greater quality. At the end of the item description where spaces are marked “MFR” and “Model #,” vendors must indicate the brand and all mfr/model numbers necessary to complete good/unit as specified. This information must be completed ONLY if bidding an alternate item.
3. Vendors bidding an alternate item must submit manufacturer’s specifications with bid response.
4. Bidders must comply with all Bid Instructions (see pages 4 - 8, including Item 7 – Freight Charge FOB Destination on page 4.
5. Special programs offered for educational training should be submitted on a separate form.
6. Contact the AIDT Business Office Purchasing Assistant with questions concerning this bid and/or specifications: Ashley Price @ 334-280-4434 or aprice@aidt.edu
7. AIDT is seeking to award this bid for one year, with the option to roll over for up to four additional years.

CHECKLIST FOR BID SUBMISSION
(Vendor does not have to return this form with bid response)

SUBMIT WITH BID PROPOSAL:	✓
Bid Contact Sheet (p. 9)	
Vendor Agreement Sheet (p.10)	
Qualification Statement (p. 11)	
Current W-9 (August 2013, issued by IRS):	
Vendor Disclosure:	
E-Verify	
Alabama Immigration Compliance Form	
Bid Proposal – RESPONSE	
SUBMIT WITH BID PROPOSAL, as applicable	
Copy of current state, county or city business license, general contractor’s license or applicable license as required by law	
Copy of General Liability (umbrella) insurance - The coverage must be in effect for the contract period. The copy must show amount limits for automobile, workmen’s compensation, etc. (applicable for the delivery of materials, supplies, etc.). Vendor is responsible for all losses/damages caused by its employees.	
Descriptive/technical literature with bid proposal when bidding alternate items. The brands and model numbers referenced in bid provides a level of quality, and unless otherwise specified, are not restrictive. Reference to a website or literature with a previous bid will not satisfy this requirement. (If Applicable)	
Descriptive/technical literature package must include a full description of the items to including a minimum of manufacturer’s name, model number and full descriptive literature. Please note company name, FEIN, complete mailing address, bid number and opening date in the upper left corner of substitute specifications. (If Applicable)	
Failure to include descriptive literature with the bid proposal could result in bid rejection. Physical inspection and operational evaluation of equipment may also be required without cost or obligation to AIDT before award is made.	
<u>Bonds Required for Various Bid Solicitations:</u>	
<ol style="list-style-type: none"> 1) Requirement for bonds, other than those projects covered by Title 39 of the <i>Code of Alabama, 1975</i>, as amended, will be specifically stated in the bid solicitation. 2) Bid bonds, when required, must be submitted with the bid proposal. 3) Performance bonds, when required, must be submitted within five (5) working days after notification of a bid award. Bond amount will be specifically stated in the bid solicitation. 	

INSTRUCTIONS TO BIDDERS

1. ***"All bids shall be sealed when received"*** (The Code of Alabama 1975, Section 41-16-54) Bids delivered by the vendor, United States Postal Service, Federal Express, UPS, Email **BID@AIDT.EDU** or other delivery service **must be identified on front of the envelope in the lower left corner with the bid number, opening date and time indicated.** It is the responsibility of the vendor to have the bid proposal delivered to the correct addressee and location.
2. Bids must be received no later than date and time indicated on the bid solicitation. Late bids or improperly submitted bids will not be considered.
3. All information shall be entered in ink, typewritten or computer generated in the appropriate space on the forms. An authorized company representative must sign the bid in ink.
4. This proposal is to be made without connection with any other person, company, or parties making a bid or proposal and is to be in all respects fair and in good faith, without collusion or fraud.
5. Bid prices are not to include tax. AIDT, a state government institution, is exempt by law from paying Alabama Sales Tax. This exemption is found in Section 40-23-4 (a) (11), Code of Alabama, and it further explained in the Sales & Use Tax Rule 810-6-3-.69.02. An exemption letter will be furnished upon request.
6. Bid is F.O.B. delivered to sites listed in specifications and additional training sites added during the contract period. Additional charges are not allowed (i.e. small order charges, fuel surcharges) and will not be paid. The successful bidder must assume all liability/responsibility for damage in transit.
7. The responsibility of determining the acceptability of any products offered rests solely with AIDT.
8. Bidder shall, at its sole expense, procure and keep in effect all necessary permits and licenses required for its performance of the requested work or service.
9. It is the responsibility of the bidder to inspect the facilities (grounds, road access, and buildings) for delivery method, installation and/or set-up of materials, supplies and/or equipment. Failure to inspect the facilities will not relieve the bidder of responsibility to provide for delivery F.O.B. or additional costs associated with delivery, installation and set up as requested in the bid.
10. AIDT terms and conditions and the laws of the State of Alabama shall govern any contract resulting from this bid.

11. Bidders desiring further information or interpretation of plans or specifications must make requests in writing to AIDT, Attn: **Ashley Price, One Technology Court, Montgomery, Alabama 36116**, or email **aprice@aidt.edu** at least five (5) days prior to bid opening. Answers to such requests will be given to all recorded bidders, in addendum form, which will be included as part of the contract documents.
12. References in the specifications to name brands, catalog numbers, etc., are for identification purposes only and in no way are intended to eliminate or discourage the offering of substitute items which exceed or equal the specifications.
13. When the bidder does not state a brand name or catalog number it is understood the offer is exactly as specified.
14. **VENDOR RESPONSIBILITY:** It is the responsibility of all bidding vendors to read this document in its entirety and to comply with all instructions, specifications and terms and conditions of the bid.
15. **BID RESPONSES:**
 - BID INFORMATION:** All information shall be entered in ink or type written in the appropriate space on the form. Bids must be signed in ink by an authorized individual on the Qualification Statement and returned to AIDT. Mistakes may be crossed out and corrections inserted before submission of the bid. **The person signing the bid must initial corrections, in ink.**
 - BID SUBMITTED:** Bids must be submitted on the forms provided to ensure complete uniformity of wording of all proposals. Bids may be rejected if they show any omissions, alterations in wording, conditional clauses, or irregularities of any kind.
 - IDENTIFICATION:** Reference Page 4, Item 1: The U.S. Postal Service may apply bar code labels on envelopes which may conceal bid identification if shown other than the lower left corner. As a result, bids can be rejected if not properly identified.
 - CLARIFICATION OF RESPONSE:** All responses will be reviewed for compliance with the mandatory requirements stated within the bid. AIDT Purchasing Agent may contact the vendor for clarification of any response.
18. **REQUESTED INFORMATION:** Any additional information requested from a vendor must be furnished within (3) working days from receipt of request or as specified in the bid. Failure to furnish information within time frame above will result in bid rejection. See Checklist, page 3 regarding items that must be submitted with bid proposal.
19. **ASSIGNMENT OF CONTRACT:** To assign, sublet or transfer any contract resulting from this proposal, the vendor's must receive written approval by AIDT Business

Manager.

20.CHANGES/MODIFICATIONS: Changes/modifications are allowed only by written change order approved by AIDT Purchasing Agent.

21.DELIVERY DATE: Delivery date(s) may be a factor in determining the award.

22.DELIVERY/FREIGHT: All items must be delivered to the “Ship To” address shown on the P.O. No deliveries are accepted on weekends or AIDT Holidays. The bid price must include delivery/freight as well as disposal of shipping/packaging materials.

23.NEW EQUIPMENT: All equipment must be new and unused and acceptable by the original equipment manufacturer for their maintenance.

24.MANUFACTURER/MODEL: At the end of the item where marked “MFR” and “model”, vendors must indicate the manufacturer & all stock/model numbers necessary to complete the unit as specified. This information must be completed unless bidding the recommended MFR/Model.

25.WARRANTY INFORMATION: Equipment shall be warranted. Vendor must specify warranty terms and conditions. The warranty shall commence on the date the equipment is delivered. Vendor will use whatever means required to facilitate this warranty, and will insure total satisfactory performance to AIDT.

26.SERVICE: Upon request for services vendor must provide parts and labor within 12 hours of notification (Monday-Friday, 7:00 am-4:00 pm).

27.FIRM PRICING: All prices quoted must be firm for the duration of the contract.

28.AWARD METHOD: Award will be made in writing to the single, lowest bidder meeting all specifications of bid. AIDT reserves the right multi-awarded any bid, if it is in the best interest of AIDT to do so. AIDT is seeking to award this bid for one year, with the option to roll over for up to four additional years.

29.CANCELLATION OF AWARD:

- AIDT reserves the right, for its convenience and without cause and without a penalty, to terminate the contract upon a thirty-(30) day written notice.
- The Contractor may terminate services upon delivery of a written thirty-(30) day notice to AIDT, Attention: Chris Brown, One Technology Court, Montgomery, AL 36116.

30.ORDERING PROCESS: Purchases from this contract will be made by purchase orders

showing specific shipping information.

31. QUALITY OF MATERIALS AND LABOR:

- Materials used that are not otherwise specified shall be the kind and quality consistent with the trade practice for such work and shall comply with all local codes.
- All labor shall be well experienced in this type work and it shall be completed in a professional manner.

32. INVOICES: Invoice(s) are to be billed in arrears in the name of AIDT to the 'BILL TO' address on the Purchase Order. Invoices may also be submitted to AIDT Finance: invoices@aidt.edu.

33. PAYMENT METHOD: Payment will be made to the successful bidder when the equipment is completely built, delivered and operational or the service has been rendered.

34. NOTE TO VENDOR: Failure to submit required documentation with bid proposal may result in bid rejection.

SALES TAX CERTIFICATION BY ALABAMA DEPARTMENT OF REVENUE

Certification Pursuant to Act Number 2021-296

Alabama Law (Section 41-4-116, Code of Alabama 1975) provides that every bid submitted and contract executed shall contain a certification that the vendor, contractor, and all of its affiliates that make sales for delivery into Alabama or leases for use in Alabama are registered, collecting, and remitting Alabama State and Local sales, use, and/or lease tax on all taxable sales and leases into Alabama. **By submitting this bid, the bidder is hereby certifying that they are in full compliance with Act Number 2021-296,** they are not barred from bidding or entering into a contract pursuant to 41-4-116, and acknowledges that the awarding authority may declare the contract void if the certification is false.

BID CONTACTS

ALL BIDDERS MUST:

- Provide the names and numbers for the contact person within your organization who will be responsible for handling customer's telephone calls, faxes, e-mails, and purchase orders. Print or type the information in the spaces below if you have only one location. If you have more than one business within the State of Alabama you must furnish a list of the current locations of each of your business in the format below.

Printed Name: _____

Job Title: _____

Address: _____

Phone: _____

Toll Free Number _____

Email _____

- List name of additional personnel to provide service/customer service. List the name, complete street address, phone number, contract person and their contact numbers.

Printed Name _____

Phone _____

Email _____

Address _____ **City** _____ **State** _____

Zip _____

Contact _____

Job Title _____

VENDOR AGREEMENT

Offer to AIDT, Montgomery, Alabama; I certify that I have read all the General Conditions and Instructions to Bidders of this bid and this offer is made without prior understanding, or connection with any entity or person submitting a bid for the same materials, supplies or equipment, and is in all respects fair and without collusion or fraud. I am authorized to sign this bid for the bidder. I agree to abide by all conditions of this bid request.

Company Name: _____

FEIN _____

Address: _____ **City:** _____ **State:** _____

Zip: _____

Signature: _____

Date: _____

Printed Name: _____

Toll Free Number: _____

Phone: _____ **Fax:** _____

Email: _____

QUALIFICATION STATEMENT

I certify that I have read all the General Conditions and Instructions to Bidders of this bid and this offer is made without prior understanding, or connection with any entity or person submitting a bid for the same materials, supplies or equipment, and is in all respects fair and without collusion or fraud. I am authorized to sign this bid for the bidder. I agree to abide by all conditions of this bid request.

Name of Company (please type or print in ink)

Authorized Signature (sign in ink)

Complete Address for Mailing Purchase Order
and Payment

Typed/Printed Name of Signature Above

City State Zip Code

Title (please type)

Telephone Number

Fax Number

NOTARIZATION

Sworn and subscribed before me this the _____ day of _____, _____

Notary Public Signature

My commission expires (date)



MINORITY INFORMATION

If this business is minority owned please qualify status below:

State of _____)
County of _____)

CERTIFICATE OF COMPLIANCE WITH THE BEASON-HAMMON ALABAMA TAXPAYER AND CITIZEN PROTECTION ACT (ACT 2011-535, as amended by ACT 2012-491)

DATE: _____

RE Contract/Grant/Incentive (describe by number or subject):

_____ by and between
_____ (Contractor/Grantee) and
_____ (State Agency, Department or Public Entity)

The undersigned hereby certifies to the State of Alabama as follows:

1. The undersigned holds the position of _____ with the Contractor/Grantee named above, and is authorized to provide representations set out in this Certificate as the official and binding act of that entity, and has knowledge of the provisions of THE BEASON-HAMMON ALABAMA TAXPAYER AND CITIZEN PROTECTION ACT (ACT 2011-535 of the Alabama Legislature, as amended by ACT 2012-491) which is described herein as "the Act."
2. Using the following definitions from Section 3 of the Act, select and initial either (a) or (b), below, to describe the Contractor/Grantee's business structure.

BUSINESS ENTITY. Any person or group of persons employing one or more persons performing or engaging in any activity, enterprise, profession, or occupation for gain, benefit, advantage, or livelihood, whether for profit or not for profit.

a. Self-employed individuals, business entities filing articles of incorporation, partnerships, limited partnerships, limited liability companies, foreign corporations, foreign limited partnerships, and foreign limited liability companies authorized to transact business in this state, business trusts, and any business entity that registers with the Secretary of State.

b. Any business entity that possesses a business license, permit, certificate, approval, registration, charter, or similar form of authorization issued by the state, any business entity that is exempt by law from obtaining such a business license, and any business entity that is operating unlawfully without a business license.

EMPLOYER. Any person, firm, corporation, partnership, joint stock association, agent, manager, representative, foreman, or other person having control or custody of any employment, place of employment, or of any employee, including any person or entity employing any person for hire within the State of Alabama, including a public employer. This term shall not include the occupant of a household contracting with another person to perform casual domestic labor within the household.

(a) The Contractor/Grantee is a business entity or employer as those terms are defined in Section 3 of the Act.

____ (b) The Contractor/Grantee is not a business entity or employer as those terms are defined in Section 3 of the Act.

3. As of the date of this Certificate, the Contractor/Grantee does not knowingly employ an unauthorized alien within the State of Alabama and hereafter it will not knowingly employ, hire for employment, or continue to employ an unauthorized alien within the State of Alabama;
4. The Contractor/Grantee is enrolled in E-Verify unless it is not eligible to enroll because of the rules of that program or other factors beyond its control.

Certified this _____ day of _____ 20____.

Name of Contractor/Grantee/Recipient

By: _____

Its _____

Title

The above Certification was signed in my presence by the person whose name appears above, on

This _____ day of _____ 20____.

WITNESS: _____
Signature

Printed Name of Witness

VENDOR DISCLOSURE STATEMENT INFORMATION AND INSTRUCTIONS

Section 41-16-82, *Code of Alabama* 1975 requires the disclosure statement to be completed and filed with all proposals, bids, contracts, or grant proposals to the State of Alabama in excess of \$5,000. The disclosure statement is not required for contracts for gas, water, and electric services where no competition exists, or where rates are fixed by law or ordinance. In circumstances where a contract is awarded by competitive bid, the disclosure statement shall be required only from the person receiving the contract and shall be submitted within ten (10) days of the award.

A copy of the disclosure statement shall be filed with the awarding entity and the Department of Examiners of Public Accounts, and if it pertains to a state contract, a copy shall be submitted to the Contract Review Permanent Legislative Oversight Committee. The address for the Department of Examiners of Public Accounts is as follows: 50N. Ripley Street, Room 3201, Montgomery, Alabama 36130-2101. If the disclosure statement is filed with a contract, the awarding entity should include a copy with the contract when it is presented to the Contract Review Permanent Legislative Oversight Committee.

Pursuant to Section 41-16-84 (b), *Code of Alabama* 1975 the State of Alabama shall not enter into any contract or appropriate any public funds with any person who refuses to provide information as required.

Pursuant to Section 41-16-86, *Code of Alabama* 1975, any person who knowingly provides misleading or incorrect information on the disclosure statement shall be subject to a civil penalty of ten percent (10%) of the amount of the transaction, not to exceed \$10,000.00. Also, the contract or grant shall be voidable by the awarding entity.

Definitions as Provided in Section 41-16-81, *Code of Alabama* 1975

- 1. Family Member of a Public Employee** – The spouse or a dependent of the public employee.

- 2. Family Member of a Public Official** – The spouse, a dependent, an adult child and his or her spouse, a parent, a spouse's parents, or a sibling and his or her spouse, of the public official.

- 3. Family Relationship** – A person has a family relationship with a public official or public employee if the person is a family member of the public official or public employee.

- 4. Person** – An individual, firm, partnership, association, joint venture, cooperative, or corporation, or any other group or combination acting in concert.

- 5. Public Official and Public Employee** - These terms shall have the same meanings ascribed to them in Sections 36-25-1(23) and 36-25-1(24), *Code of Alabama* 1975, (see below) except for the purposes of the disclosure requirements of this article, the terms shall only include persons in a position to influence the awarding of a grant or contract who are affiliated with the awarding entity. Notwithstanding the foregoing, these terms shall also include the Governor, Lieutenant Governor, members of the cabinet of the Governor, and members of the Legislature. (Note: The definitions for public official and public employee are now denoted as Sections 36-25-1 (25) and 36-25-1 (26), *Code of Alabama* 1975. However, Section 41-16-86 (5), *Code of Alabama* 1975 has not been codified to reflect such updates.)

Section 36-25-1(25), *Code of Alabama* 1975, defines a **public employee** as any person employed at the state, county or municipal level of government or their instrumentalities, including governmental corporations and authorities, but excluding employees of hospitals or other health care corporations including contract employees of those hospitals or other health care corporations, who is paid in whole or in part from state, county, or municipal funds. For purposes of this chapter, a public employee does not include a person employed on a part-time basis whose employment is limited to providing professional services other than lobbying, the compensation for which constitutes less than 50 percent of the part-time employee's income.

Section 36-25-1(26), *Code of Alabama* 1975, defines a **public official** as any person elected to public office, whether or not that person has taken office, by the vote of the people at state, county, or municipal level of government or their instrumentalities, including governmental corporations, and any person appointed to a position at the state, county, or municipal level of government or their instrumentalities, including governmental corporations. For purposes of this chapter, a public official includes the chairs and vice-chairs or the equivalent offices of each state political party as defined in Section 17-13-40, *Code of Alabama* 1975.

Instructions

Complete all lines as indicated. If an item does not apply, denote N/A (not applicable). If you cannot include required information in the space provided, attach additional sheets as necessary.

THE DISCLOSURE STATEMENT MUST BE SIGNED, DATED, AND NOTARIZED PRIOR TO SUBMISSION.



State of Alabama

Disclosure Statement

Required by Article 3B of Title 41, Code of Alabama 1975

ENTITY COMPLETING FORM

ADDRESS

CITY, STATE, ZIP

TELEPHONE NUMBER

STATE AGENCY/DEPARTMENT THAT WILL RECEIVE GOODS, SERVICES, OR IS RESPONSIBLE FOR GRANT AWARD

AIDT

ADDRESS

One Technology Court

CITY, STATE, ZIP

TELEPHONE NUMBER

Montgomery, AL 36116

334-242-0299

This form is provided with:

- Contract
 Proposal
 Request for Proposal
 Invitation to Bid
 Grant Proposal

Have you or any of your partners, divisions, or any related business units previously performed work or provided goods to any State Agency/Department in the current or last fiscal year?

- Yes
 No

If yes, identify below the State Agency/Department that received the goods or services, the type(s) of goods or services previously provided, and the amount received for the provision of such goods or services.

STATE AGENCY/DEPARTMENT	TYPE OF GOODS/SERVICES	AMOUNT RECEIVED

Have you or any of your partners, divisions, or any related business units previously applied and received any grants from any State Agency/Department in the current or last fiscal year?

- Yes
 No

If yes, identify the State Agency/Department that awarded the grant, the date such grant was awarded, and the amount of the grant.

STATE AGENCY/DEPARTMENT	DATE GRANT AWARDED	AMOUNT OF GRANT

1. List below the name(s) and address(es) of all public officials/public employees with whom you, members of your immediate family, or any of your employees have a family relationship and who may directly personally benefit financially from the proposed transaction. Identify the State Department/Agency for which the public officials/public employees work. (Attach additional sheets if necessary.)

NAME OF PUBLIC OFFICIAL/EMPLOYEE	ADDRESS	STATE DEPARTMENT/AGENCY

2. List below the name(s) and address(es) of all family members of public officials/public employees with whom you, members of your immediate family, or any of your employees have a family relationship and who may directly personally benefit financially from the proposed transaction. Identify the public officials/public employees and State Department/Agency for which the public officials/public employees work. (Attach additional sheets if necessary.)

NAME OF FAMILY MEMBER	ADDRESS	NAME OF PUBLIC OFFICIAL/ PUBLIC EMPLOYEE	STATE DEPARTMENT/ AGENCY WHERE EMPLOYED

If you identified individuals in items one and/or two above, describe in detail below the direct financial benefit to be gained by the public officials, public employees, and/or their family members as the result of the contract, proposal, request for proposal, invitation to bid, or grant proposal. (Attach additional sheets if necessary.)

Describe in detail below any indirect financial benefits to be gained by any public official, public employee, and/or family members of the public official or public employee as the result of the contract, proposal, request for proposal, invitation to bid, or grant proposal. (Attach additional sheets if necessary.)

List below the name(s) and address(es) of all paid consultants and/or lobbyists utilized to obtain the contract, proposal, request for proposal, invitation to bid, or grant proposal:

NAME OF PAID CONSULTANT/LOBBYIST	ADDRESS

By signing below, I certify under oath and penalty of perjury that all statements on or attached to this form are true and correct to the best of my knowledge. I further understand that a civil penalty of ten percent (10%) of the amount of the transaction, not to exceed \$10,000.00, is applied for knowingly providing incorrect or misleading information.

Signature Date

Notary's Signature Date Date Notary Expires

Article 3B of Title 41, Code of Alabama 1975 requires the disclosure statement to be completed and filed with all proposals, bids, contracts, or grant proposals to the State of Alabama in excess of \$5,000.

AIDT ITB 989 - Aluminum

Request is being made for quotes on the items referenced, below. Consideration must be given to the following items when submitting a bid response:

- 1) Prices for quoted item must remain at stated bid price for no less than 6 months at a time.
- 2) Price increases are subject to AIDT approval at the end of each six-month period.
- 3) Vendor must also be willing to immediately pass on cost savings due to decreases in market prices.
- 4) This bid is subject to a multi-year rollover, not to exceed a total of three calendar years from the date of award. Vendor will be provided an option to continue/opt out as an awarded supplier at any time during the bid term, with a 30 day notice to AIDT, in writing; or vendor may continue/opt out upon annual renewal notification (approximately August, annually).
- 5) This bid is not intended to be all-inclusive. Vendor must be willing to provide comparable pricing on any item not specifically stated, but for which there is a need.
- 6) AIDT reserves the right to issue multiple awards, as may be in the best interest of the agency, in order to insure that adequate supply is available in a timely manner for the various training facilities, located statewide.

AIDT ITB 989 - Aluminum
SPECIFICATIONS

ITEM NUMBER	DESCRIPTION	BID AMOUNT
0001	.080 6061 in anywhere from 4ft x 8ft to 5ft x 12ft	
0002	.063 3003 4ft x 8ft.	
0003	.250 6061 in 6in x 12ft.	
0004	.313 6061 in 12in x 12ft.	
0005	.032 3003 in 4ft x 8ft.	
0006	.063 1x1 angle 12ft	

AIDT ITB 989- Aluminum

Purchases from this bid will be for any of the training locations listed below and will be made available to any AIDT location not specifically listed, or any AIDT location added during the term of this award:

AIDT Location	Street Address	City, State Zip
AIDT - Montgomery	One Technology Court	Montgomery, AL 36116
AIDT - Hyundai Training Center	900 Hyundai Boulevard	Montgomery, AL 36105
AIDT - Mercedes Training Center	9 Mercedes Drive	Vance, AL 35490
AIDT- Maritime Training Center	Addsco Road	Mobile, AL 36602
AIDT - Airbus Training Center	1815 Ninth Street, Brookley Complex	Mobile, AL 36615
AIDT - Robotics Technology Park	6505 US Hwy 31	Tanner, AL 35671

Assessment Plate (1)- 112mm x 162mm x .100"

Assessment Plate (2)- 112mm x 202mm x .100"

Assessment Plate (3)- .100" x 6.40" x 4.40"

Assessment Plate (4)- 8.4" x 4.4" x .100"

Assessment Plate (5)- 7.95" x 4.41" x .100"

Curve Plate - "The initial dimensions of the aluminum plate should be 10" x 6" x .063". The curve should be .5" so that the final dimension of the plate should be 9.5" x 6" with a .5" pitch."

Match Drilling Required

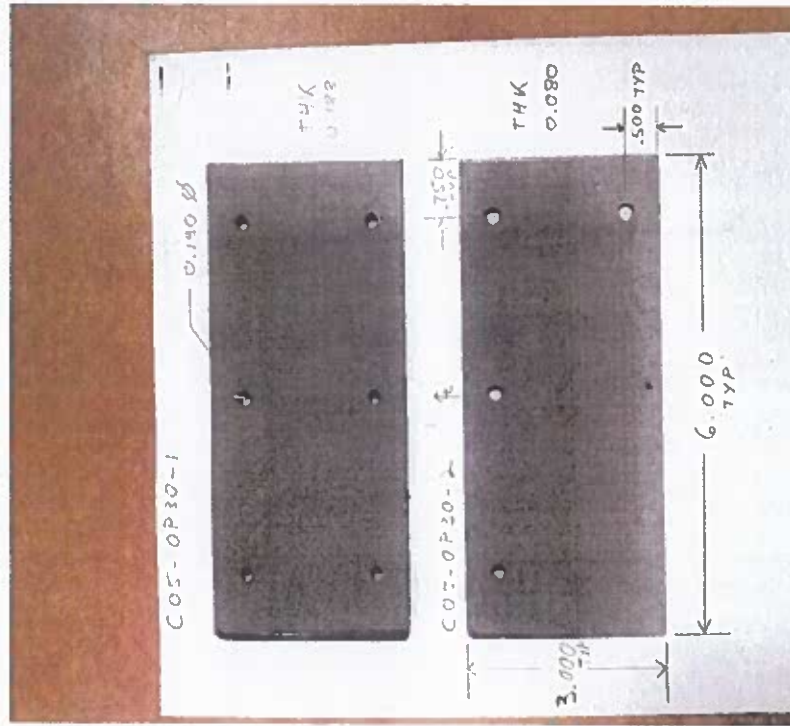

A220

CØ5-OP1Ø-1
Project A-3

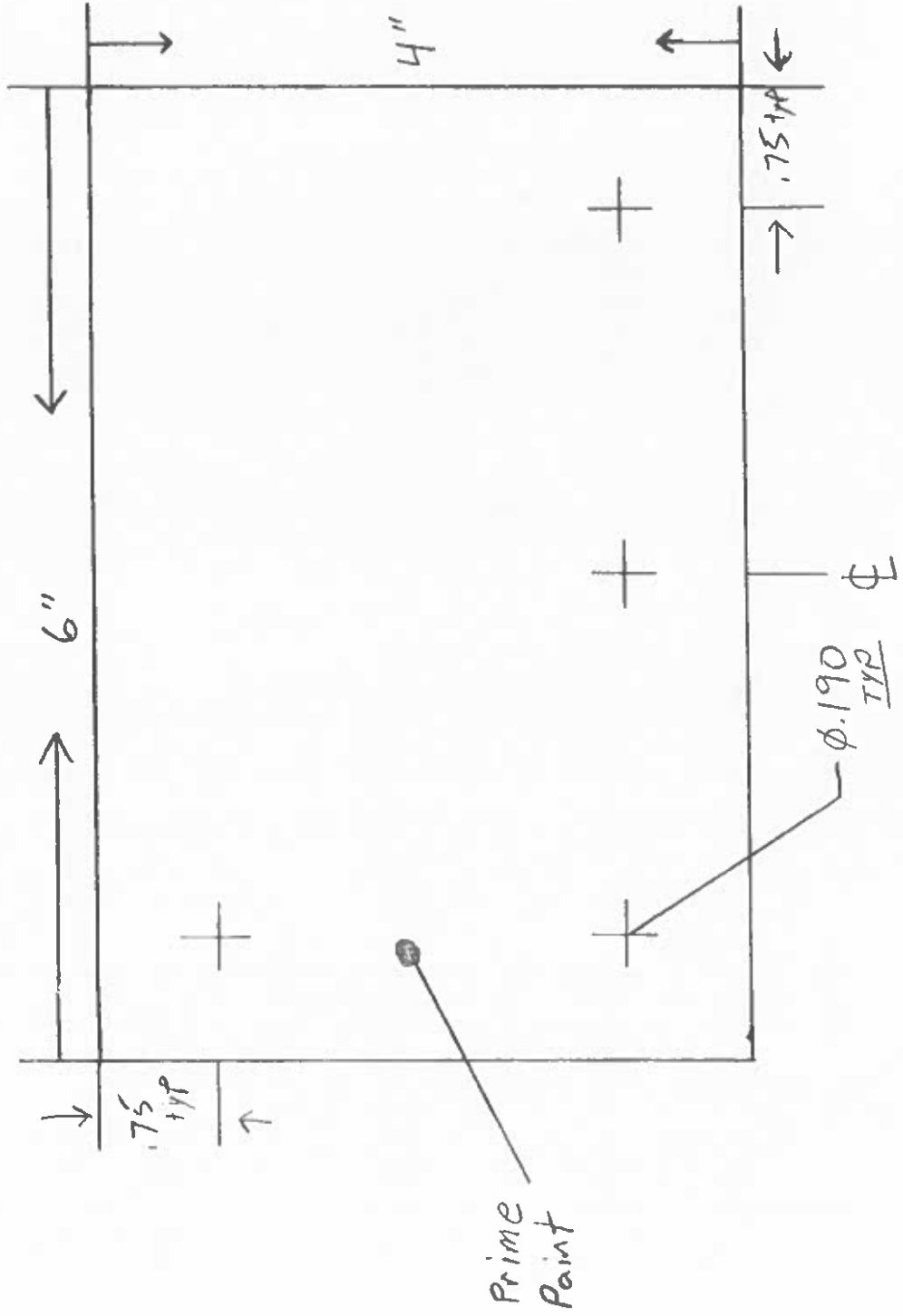

Sealant/Connector Plate

AEP 6x6_.250_1_--

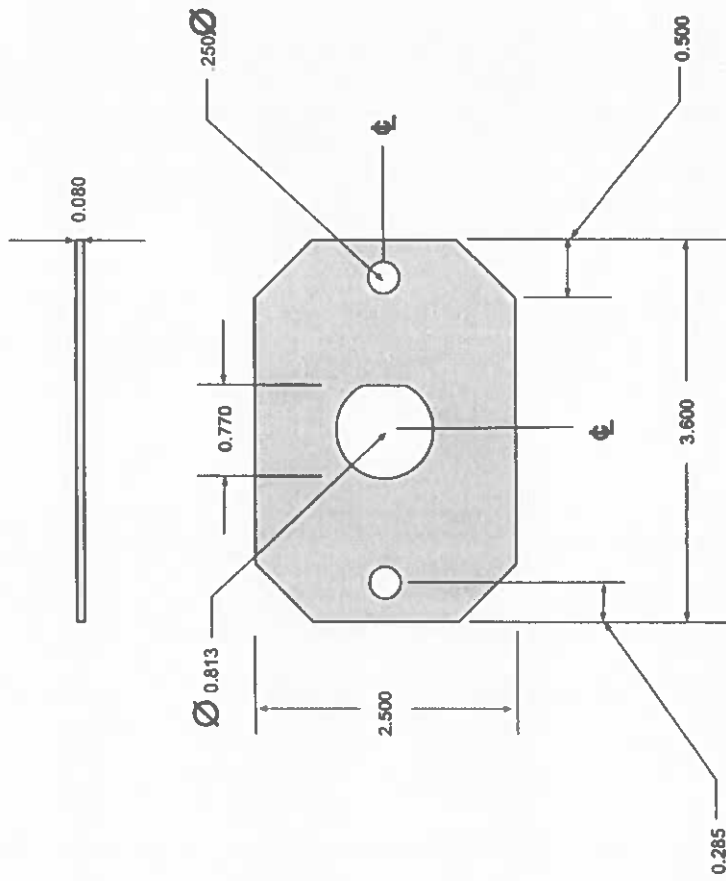

A220

© Airbus Inc. Tous droits réservés

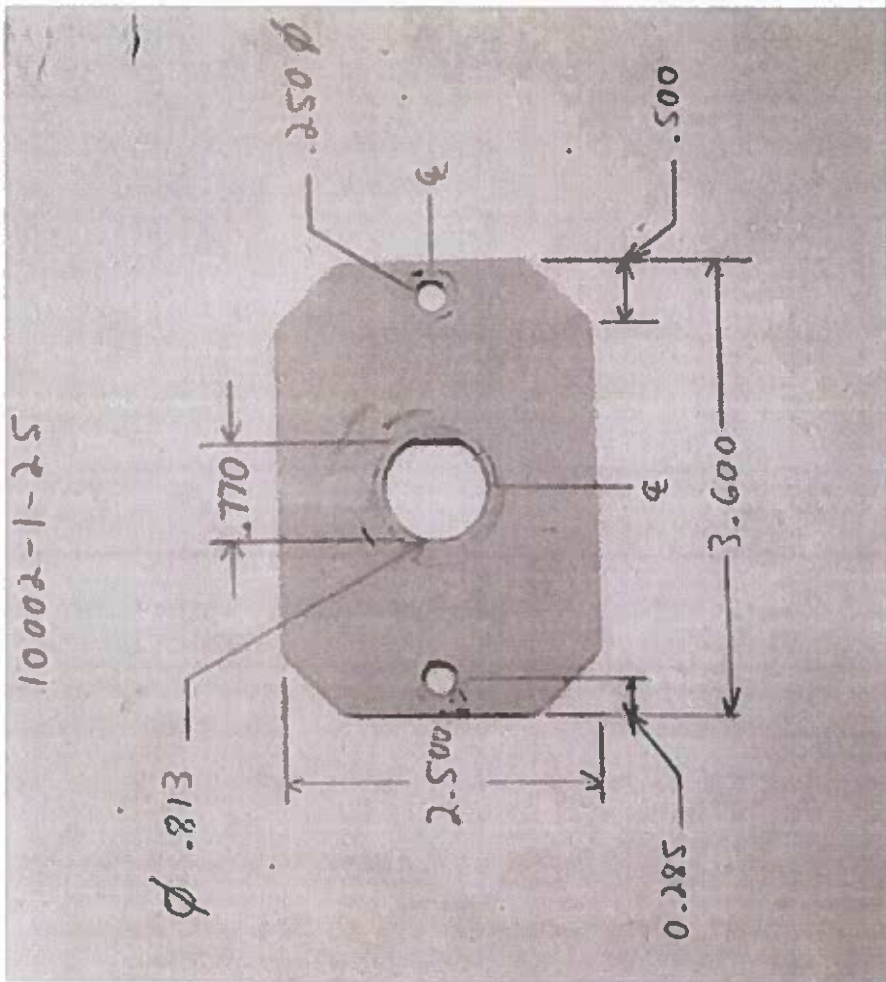

COS-OP20-1

AEP 3x6_.250_1_--

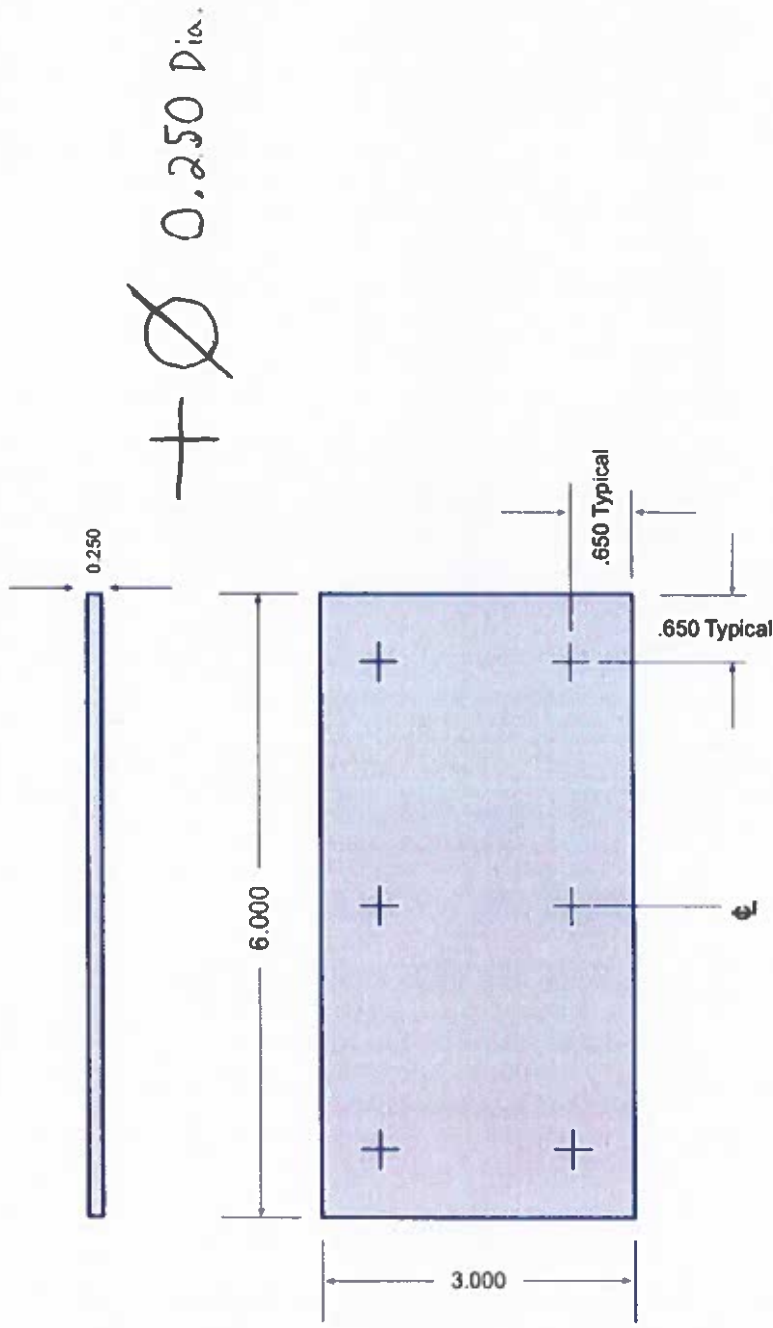

AIRBUS

PRIVÉ ET CONFIDENTIEL / Private and Confidential
© Airbus Inc. ou ses filiales / and Subsidiaries. Tous droits réservés. / All Rights Reserved
© Airbus Inc. Tous droits réservés

C05 -- OP20-2

AEP 3x6 .080 1_-

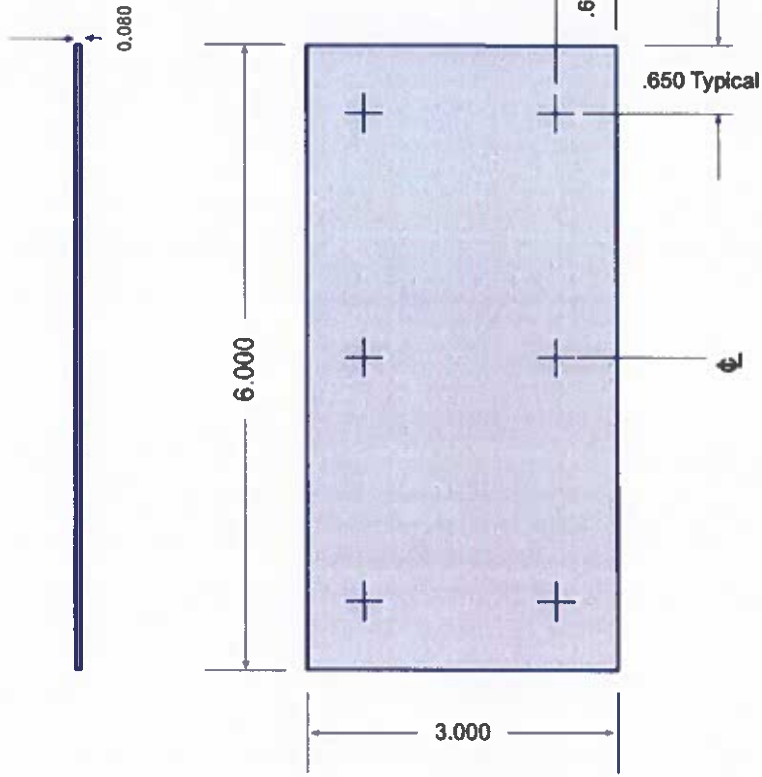

AIRBUS

PRIVÉ ET CONFIDENTIEL / Private and Confidential
© Airbus Inc. ou ses filiales / and Subsidiaries. Tous droits réservés. / All Rights Reserved
© Airbus Inc. Tous droits réservés

Final Plate

+Ø 0.250 Dia.

AEP 6x6_.250_1_--

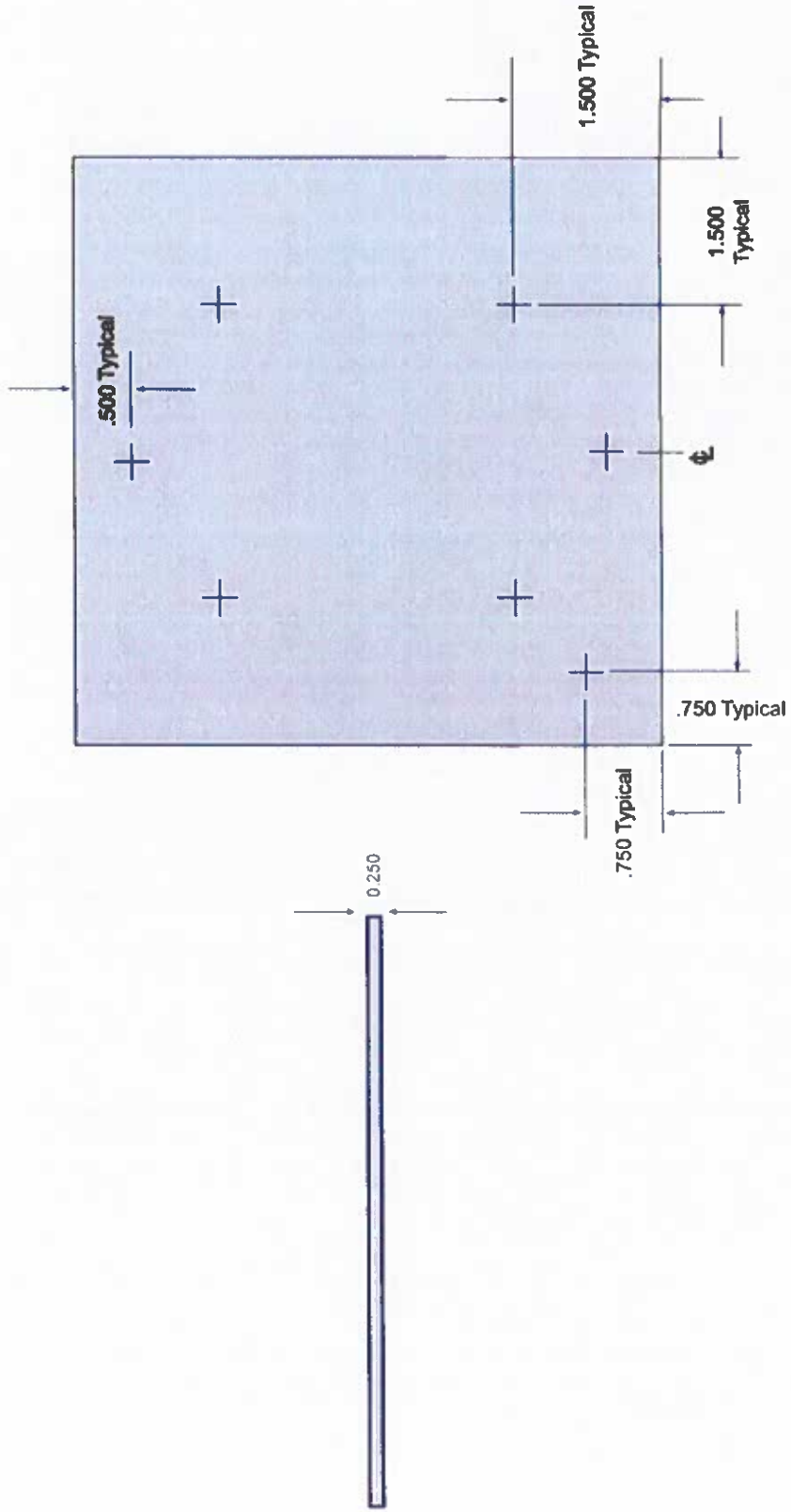

© Airbus Inc. Tous droits réservés

A220

Notes : Material : Metal plate 6061-T6
 0,080" THK
 Cut to size & deburr
 NO PAINT REQUIRED
 Identification : Ink stamp, black

Tolerances except as noted otherwise All dimensions are in inches Angles +/- 1/2 degrees Linear tolerances 0.XX = 0.03 / 0.XXX = 0.010	AIRBUS	Drawn by B. St-Onge
	Plate	Part number : Pa-f

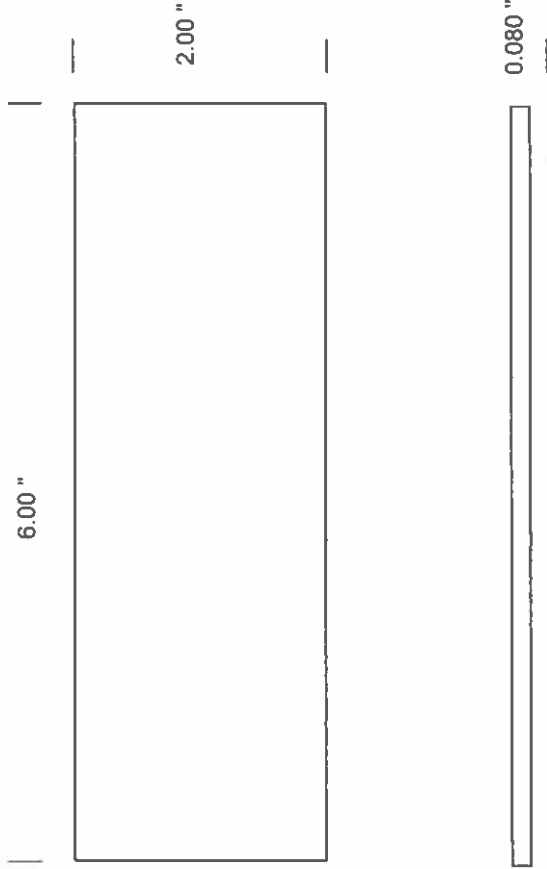

Tolerances except as noted otherwise
All dimensions are in inches
Angles +/- 1/2 degrees
Linear tolerances
0.XX = 0.03 / 0.XXX = 0.010

BOMBARDIER

Plate

Drawn by B. St-Onge

Part number : **587-G**

Notes : Material : Metal plate 6061 - T6
Cut to size & deburr
Irridite or alodine treatment
Green primer
Identification : Ink stamp, black

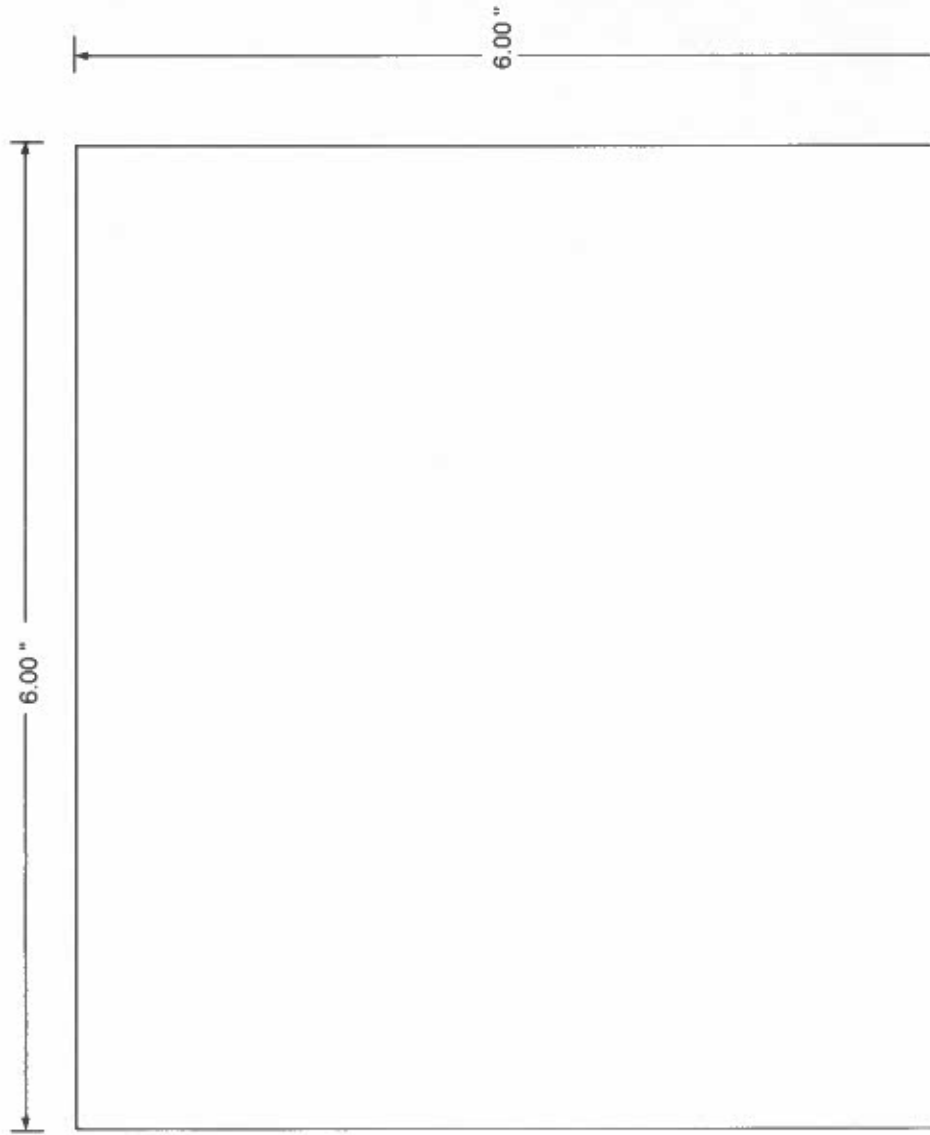

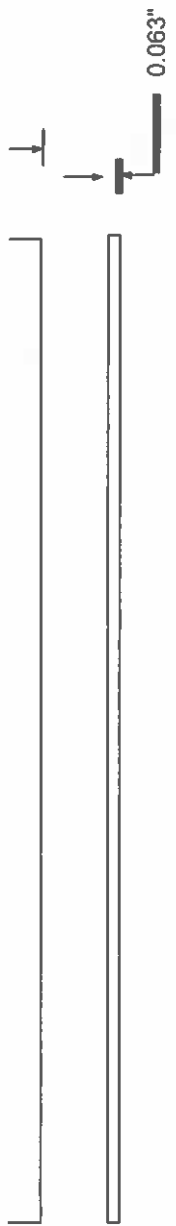



Tolerances except as noted otherwise
All dimensions are in inches
Angles +/- 1/2 degrees
Linear tolerances
0 XX = 0.03 / 0 XXX = 0.010

AIRBUS

Plate

Drawn by B. St-Onge

Part number : 587-A

Notes : Material : Metal plate 6061 - T6
Cut to size & deburr
Irridite or alodine treatment
Green primer
Identification : Ink stamp, black

6.00"

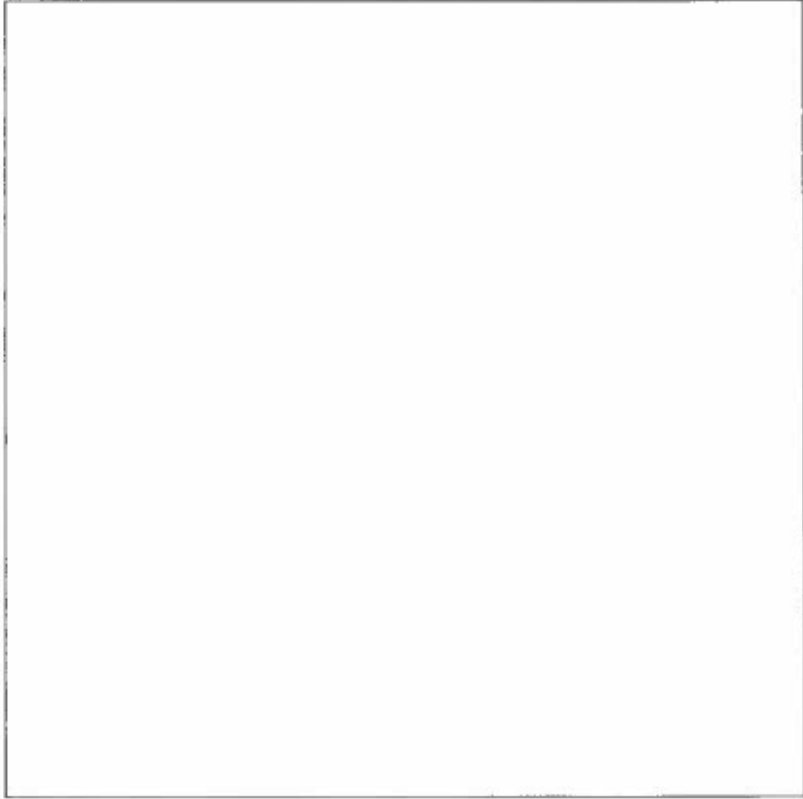

6.00 "

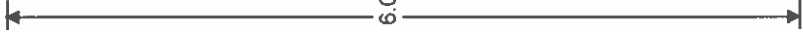

0.250 "



Tolerances except as noted otherwise
All dimensions are in inches
Angles +/- 1/2 degrees
Linear tolerances
0.XX = 0.03 / 0.XXX = 0.010

AIRBUS

Plate

Drawn by B. St-Onge

Part number : 587-B

Notes : Material : Metal plate 6061 - T6
Cut to size & deburr
Irridite or alodine treatment
Green primer
Identification : Ink stamp, black

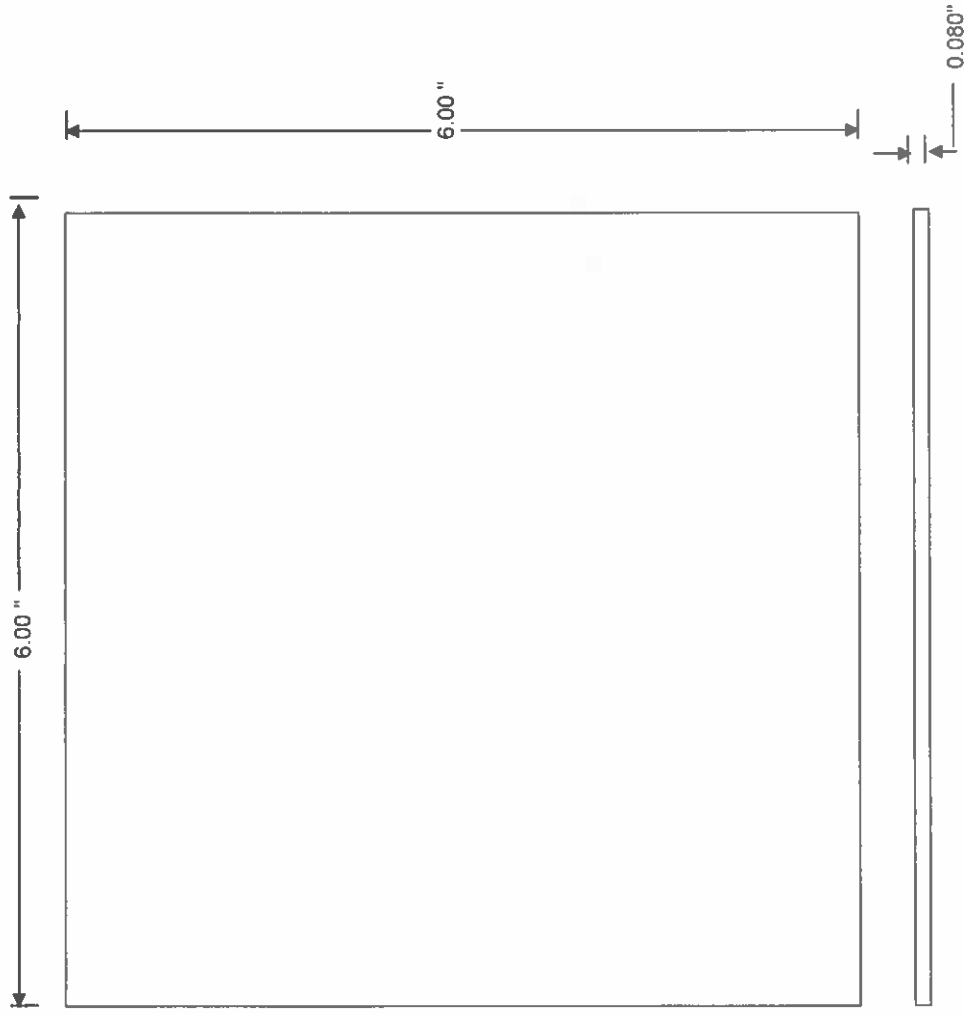

Tolerances except as noted otherwise
All dimensions are in inches
Angles +/- 1/2 degrees
Linear tolerances
0.XX = 0.03 / 0.XXX = 0.010

AIRBUS
Plate

Drawn by B. St-Onge
Part number : **587-C**

Notes : Material : Metal plate 6061 - T6
0.032"THK
Cut to size & deburr
Irridite or alodine treatment Green primer
Identification : Ink stamp, black

6.00 "

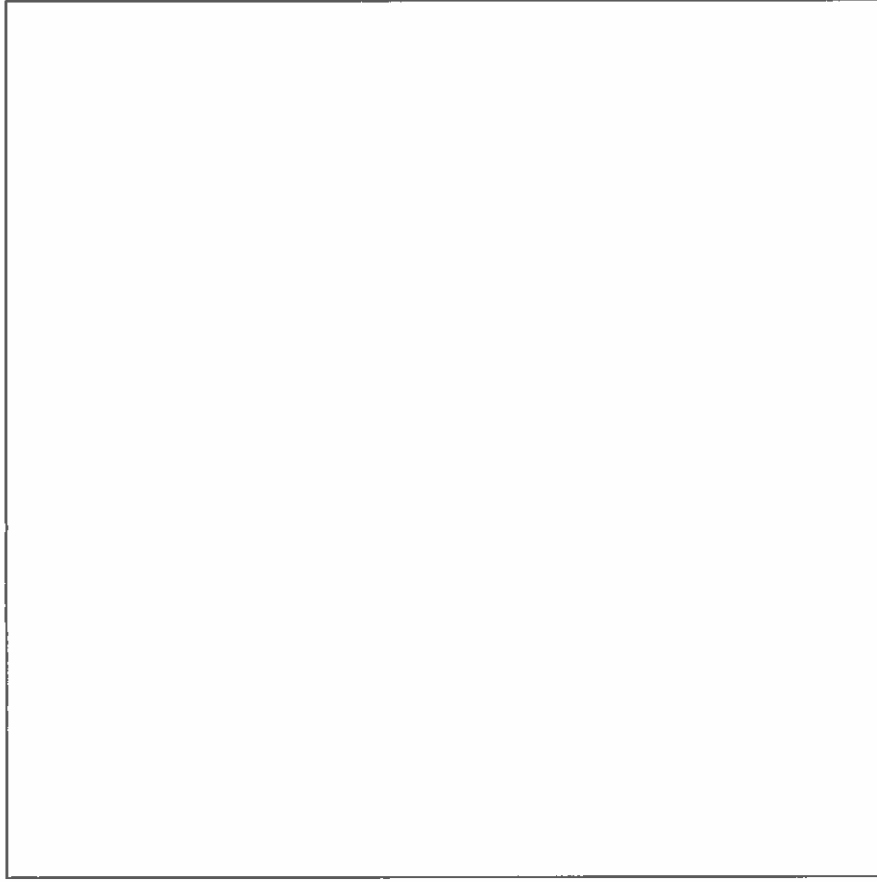

6.00 "

0.032 "



Tolerances except as noted otherwise
All dimensions are in inches
Angles +/- 1/2 degrees
Linear tolerances
0.XX = 0.03 / 0.XXX = 0.010

AIRBUS

Plate

Drawn by B. St-Onge

Part number : 587-CT-1

Notes : Material : Metal plate AMS 5599 E
0.022 - 0.025 " THK
2650 - 3 - 6745
Cut to size & deburr
NO PAINT REQUIRED
Identification : Ink stamp, black

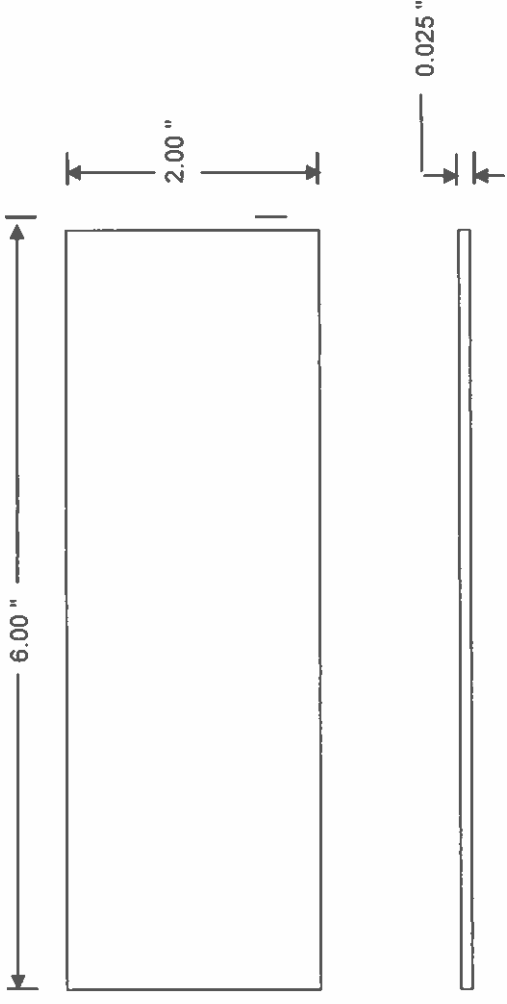

Tolerances except as noted otherwise
All dimensions are in inches
Angles +/- 1/2 degrees
Linear tolerances
0.XX = 0.03 / 0.XXX = 0.010

AIRBUS

Plate

Drawn by B. St-Onge

Part number : **587-CT-2**

Notes : Material : Metal plate AMS 4911
HT-12478 - 0,080" THK
Cut to size & deburr
NO PAINT REQUIRED
Identification : Ink stamp, black

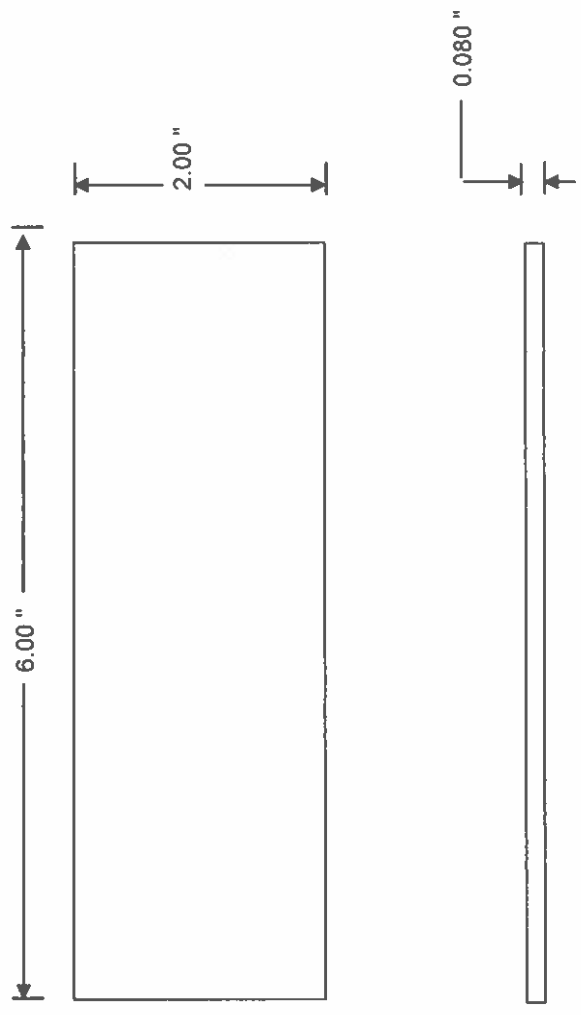

Tolerances except as noted otherwise
 All dimensions are in inches
 Angles +/- 1/2 degrees
 Linear tolerances
 0.XX = 0.03 / 0.XXX = 0.010

AIRBUS

Angle

Drawn by B. St-Onge

Part number : 587-D

Notes : Material : Extrusion 6061 - T6
 Cut to size & deburr
 Irridite or alodine treatment
 Green primer
 Identification : Ink stamp, black

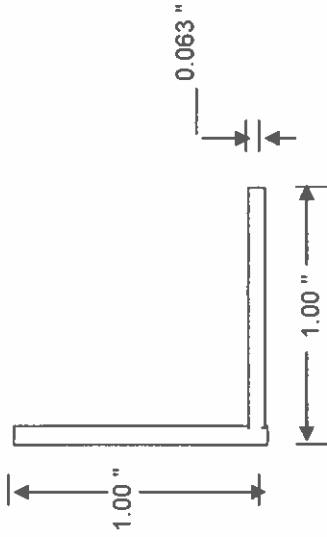

← View A

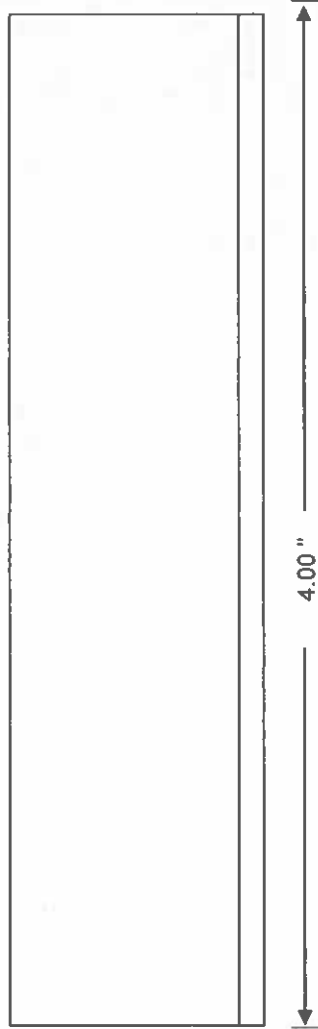

View A

Tolerances except as noted otherwise
All dimensions are in inches
Angles +/- 1/2 degrees
Linear tolerances
0.XX = 0.03 / 0.XXX = 0.010

AIRBUS

Plate

Drawn by B. St-Onge

Part number : **587-E**

Notes : Material : Metal plate 6061 - T6
Cut to size & deburr
Irridite or alodine treatment
Green primer
Identification : Ink stamp, black

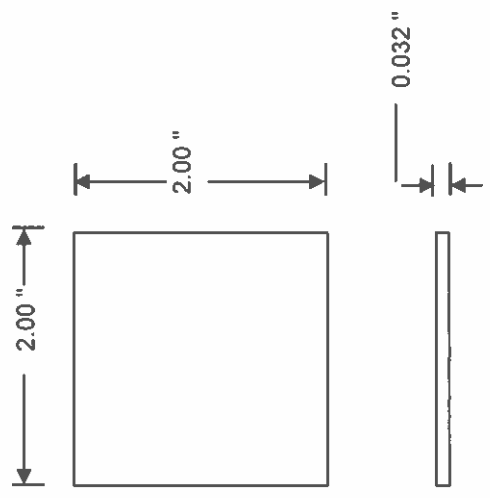

Tolerances except as noted otherwise
All dimensions are in inches
Angles +/- 1/2 degrees
Linear tolerances
0.XX = 0.03 / 0.XXX = 0.010

AIRBUS

Angle

Drawn by B. St-Onge

Part number : 587-F

Notes : Material : extrusion 6061 - T6
Cut to size & deburr
Irradite or alodine treatment
Green primer
Identification : Ink stamp, black

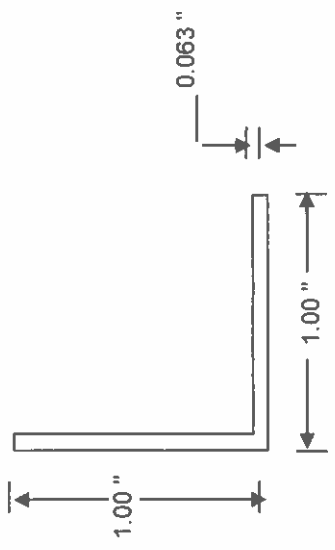

View A

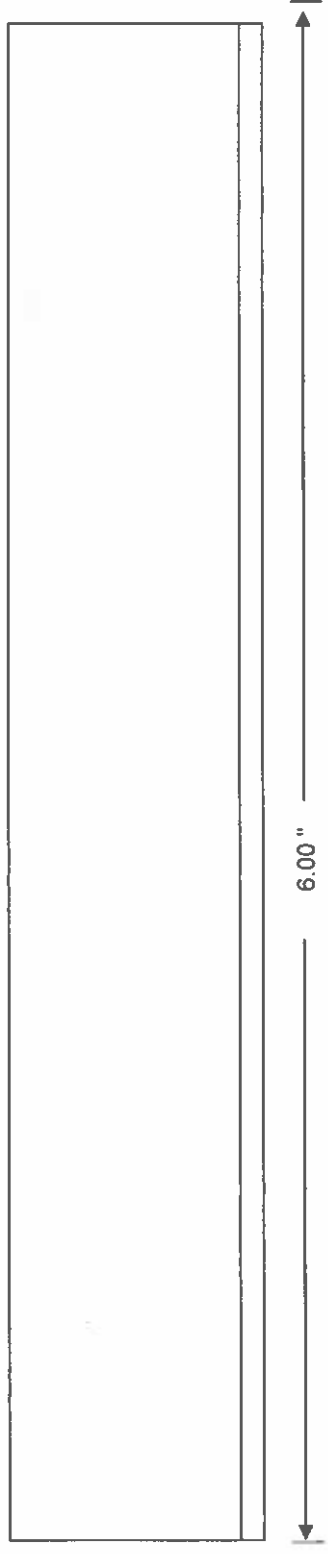

View A

Tolerances except as noted otherwise
All dimensions are in inches
Angles +/- 1/2 degrees
Linear tolerances
0.XX = 0.03 / 0.XXX = 0.010

AIRBUS

Plate

Drawn by B. St-Onge

Part number : 587-H

Notes : Material : Metal plate 6061 - T6
Cut to size & deburr
Irridite or alodine treatment
Green primer
Identification : Ink stamp, black

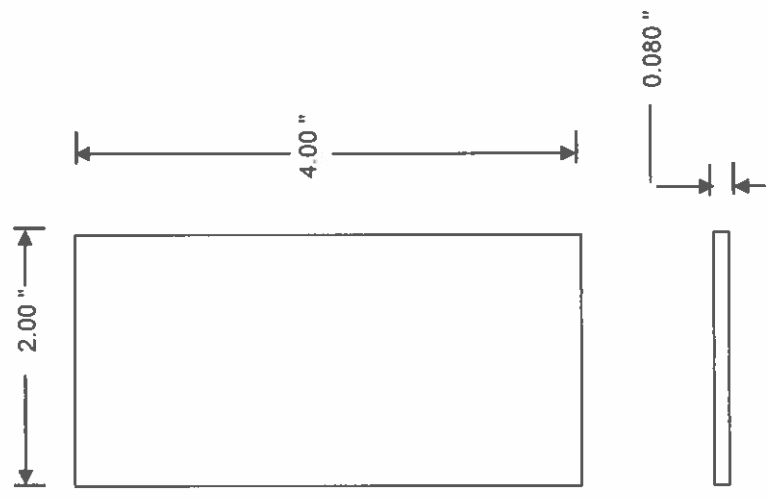

Tolerances except as noted otherwise
All dimensions are in inches
Angles +/- 1/2 degrees
Linear tolerances
0.XX = 0.03 / 0.XXX = 0.010

AIRBUS

Plate

Drawn by B. St-Onge

Part number : 587-I

Notes : Material : Metal plate 6061 - T6
Cut to size & deburr
Irridite or alodine treatment
Green primer
Identification : Ink stamp, black

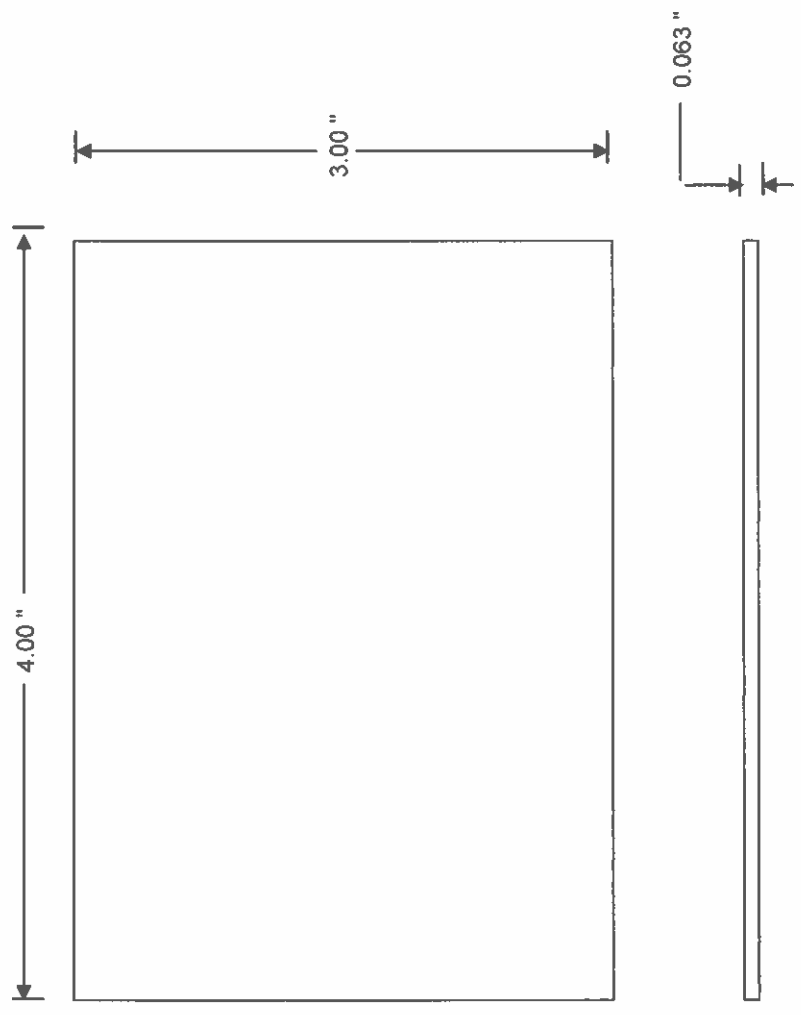

Tolerances except as noted otherwise
All dimensions are in inches
Angles +/- 1/2 degrees
Linear tolerances
0.XX = 0.03 / 0.XXX = 0.010

AIRBUS

Plate

Drawn by B. St-Onge

Part number : 587-J

Notes : Material : Metal plate 6061 - T6
Cut to size & deburr
Irridite or alodine treatment
Green primer
Identification : Ink stamp, black

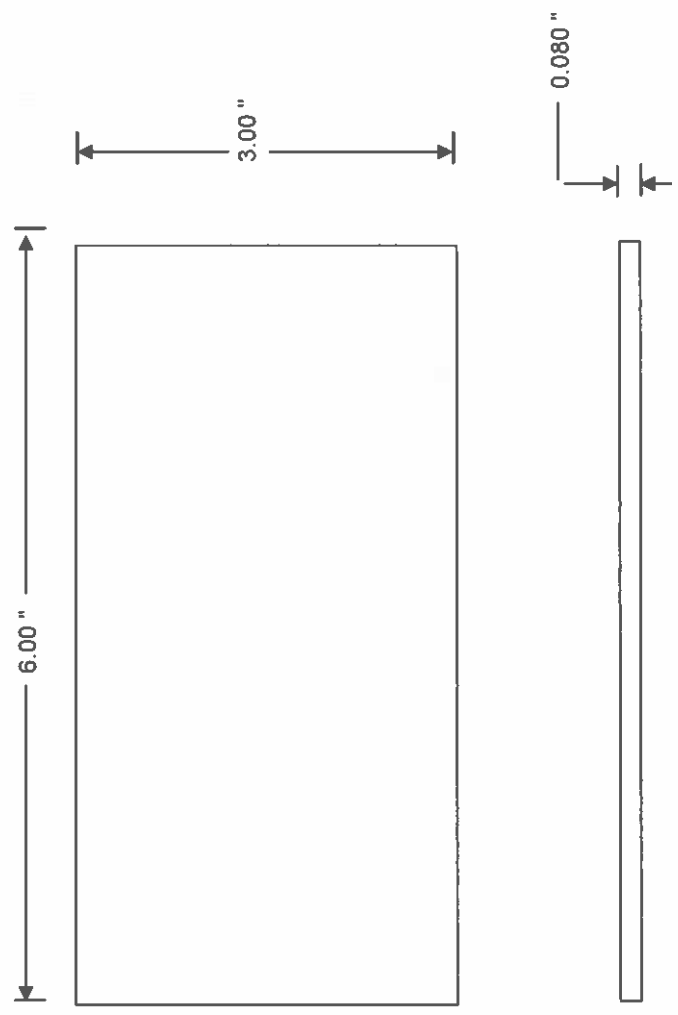

Tolerances except as noted otherwise All dimensions are in inches Angles +/- 1/2 degrees Linear tolerances 0.XX = 0.03 / 0.XXX = 0.010	BOMBARDIER	Drawn by B. St-Onge
	Plate	Part number :

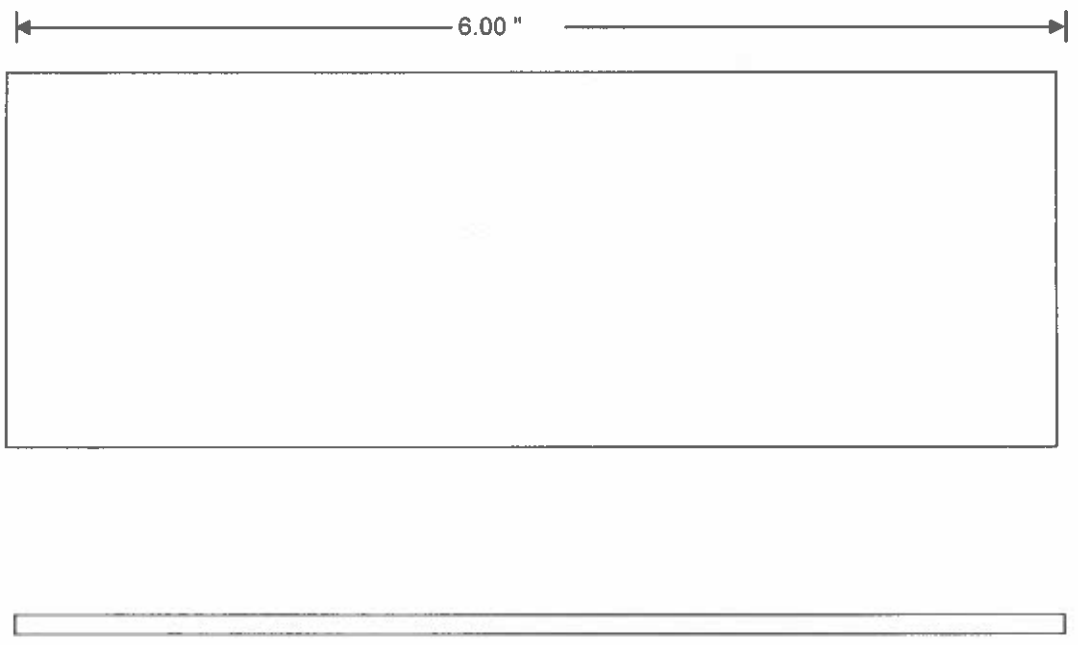

je

587-J

Notes : Material : Metal plate 6061 - T6
Cut to size & deburr
Irridite or alodine treatment
Green primer
Identification : Ink stamp, black

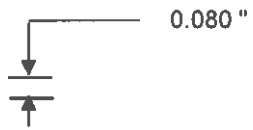

Tolerances except as noted otherwise
All dimensions are in inches
Angles +/- 1/2 degrees
Linear tolerances
0.XX = 0.03 / 0.XXX = 0.010

AIRBUS

Plate

Drawn by B. St-Onge

Part number : 587-L

Notes : Material : Metal plate 6061 - T6
Cut to size & deburr
Irridite or alodine treatment
NO PRIMER REQUIRED
Identification : Ink stamp, black

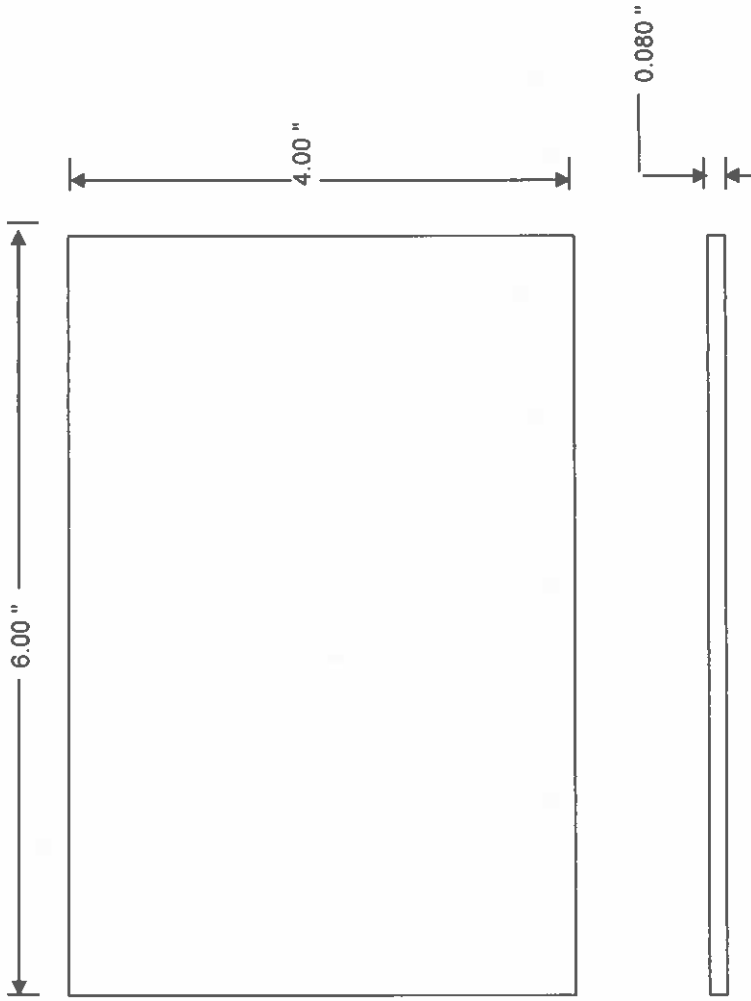

Tolerances except as noted otherwise
All dimensions are in inches
Angles +/- 1/2 degrees
Linear tolerances
0.XX = 0.03 / 0.XXX = 0.010

AIRBUS

Plate

Drawn by B. St-Onge

Part number : 587-M

Notes : Material : Metal plate 6061 - T6
Cut to size & deburr
Irridite or alodine treatment
Green primer
Identification : Ink stamp, black

7.50 "

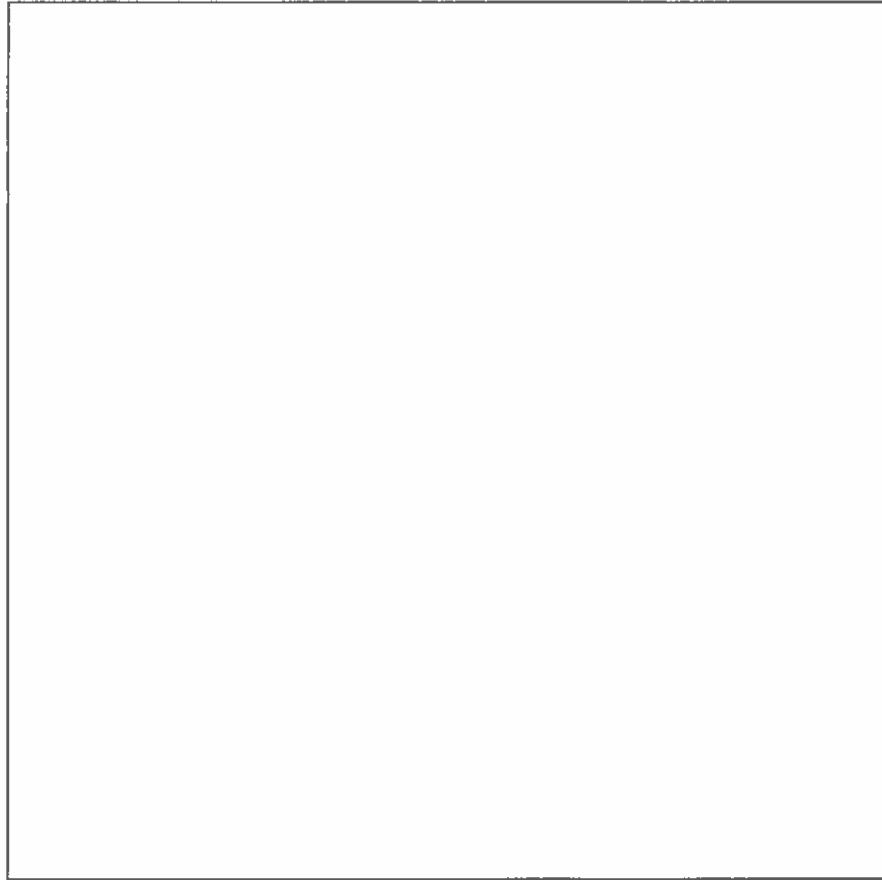

7.50 "

0.080 "



Tolerances except as noted otherwise
 All dimensions are in inches
 Angles +/- 1/2 degrees
 Linear tolerances
 0.XX = 0.03 / 0.XXX = 0.010

AIRBUS

Channel

Drawn by B. St-Onge

Part number : **587-P**

Notes : Material : Sheet metal 6061 - T6
 Cut to size & deburr
 Irridite or alodine treatment
 Green primer
 Identification : Ink stamp, black

View A →

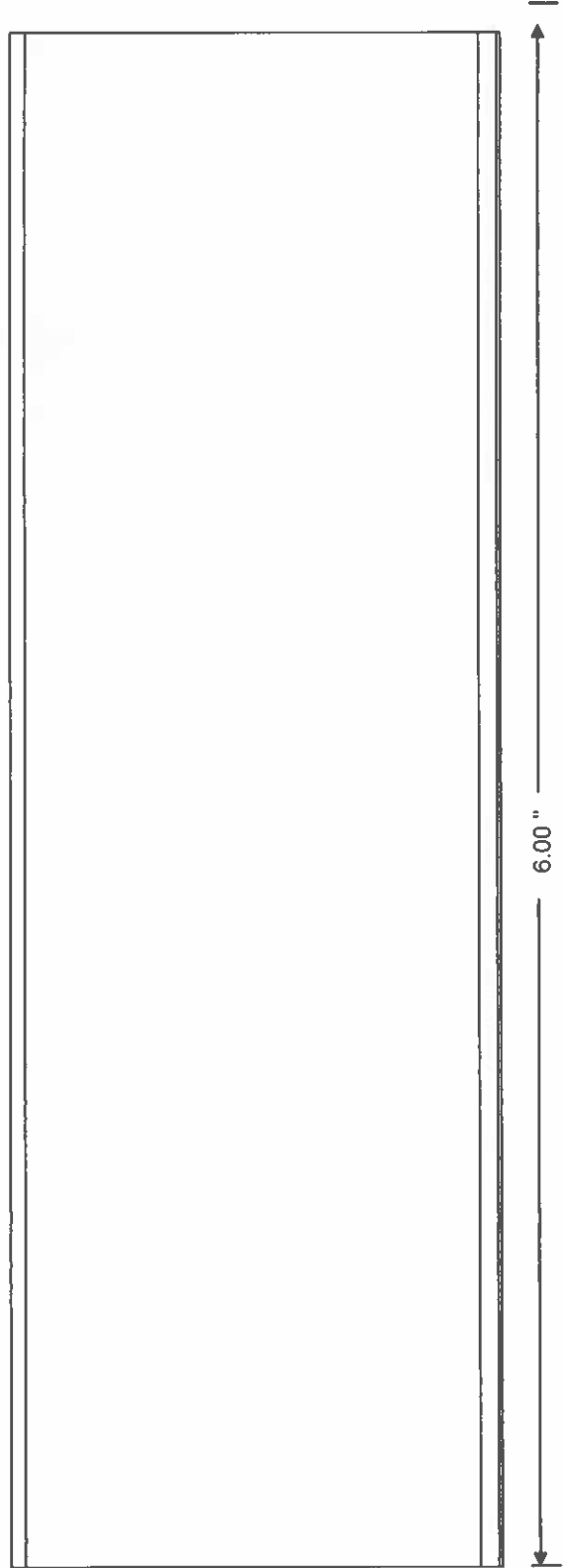
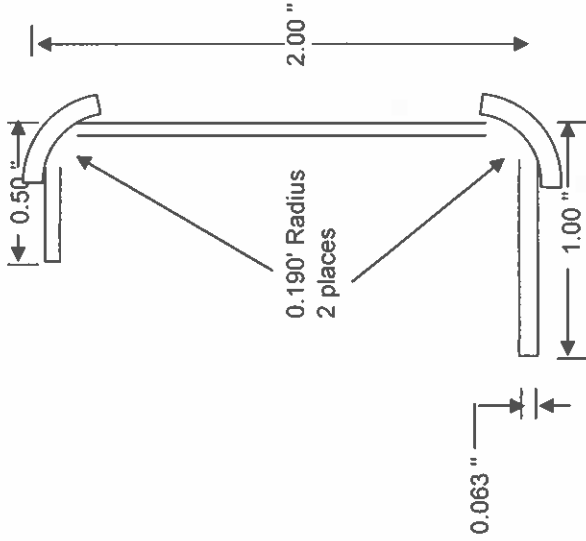

View A

Tolerances except as noted otherwise
All dimensions are in inches
Angles +/- 1/2 degrees
Linear tolerances
0.XX = 0.03 / 0.XXX = 0.010

AIRBUS

Plate

Drawn by B. St-Onge

Part number : **587-R**

Notes : Material : Metal plate 6061 - T6
Cut to size & deburr
Irridite or alodine treatment
Green Primer
Identification : Ink stamp, black

